

HYDROQUIP™

Outdoor Series INSTALLATION MANUAL

THE **SMART CHOICE**™



To ensure that the system is installed properly, provide your electrician with these instructions.

8700 Series

TABLE OF CONTENTS

System installation instructions.....	1
Connecting power to the system.....	2-7
How to connect an optional gas heater.....	8
Connecting and configuration of components.....	9-11
Programming options and instructions.....	12-13
Installing your spa light.....	14
Installing the spaside control.....	15
Starting up the system.....	16
Troubleshooting the system.....	17-18
Special Considerations.....	19
System Data Label.....	20
Warranty Information.....	21

INSTALLATION CONSIDERATIONS

Hydro-Quip 8000 Series Solid-State Systems were designed for indoor or outdoor installations. This equipment may be used for in-ground as well as aboveground spas.

- The Equipment System must be installed on a firm, level surface (ie: concrete pad)
- The area where the system is installed must have adequate drainage to prevent flooding of the equipment under all circumstances.
- For performance reasons locate the system as close to the spa as practical. (**Consult local codes for minimum distance between equipment and spa**)
- Provide adequate access around and above the System for service and maintenance. Three (3') of clearance around the equipment is recommended.
- The pump(s) provided with the system may or may not be self-priming. Pumps that are **NOT** self priming must be installed **BELOW** water level or they will not prime.
- All components such as pump, blower, etc are powered from a multi-position terminal strip inside the upper control box.

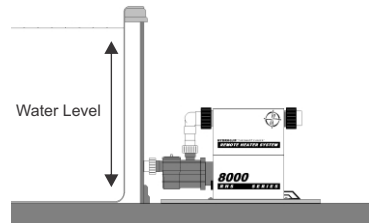
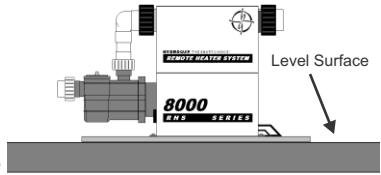

INSTALLATION INSTRUCTIONS

To assure adequate performance, the spa plumbing must be 1 1/2" minimum. The use of 2" is recommended.

There may be three separate plumbing systems in the spa. Verify the function of each pipe.

- 1) **Suction Side Plumbing** - this plumbing will connect to the spa's skimmer, main drain and suction fittings. This plumbing connects to the open end of the pump on your Equipment System.
- 2) **Discharge Side Plumbing** - this plumbing will go to the spa's hydrotherapy jet and message fittings. This plumbing connects to the open end of the heater on your Equipment System.
- 3) **Air Blower Plumbing** - this plumbing will go to an air channel under the floor or to an air distribution manifold of the spa. This plumbing connects only to an air blower.

To allow for safe operation of the spa, the suction fittings connected to the suction opening of the Equipment System should be listed or approved for the purpose.

- Each pump must be provided with two suction fittings. Pump 1 is generally attached to a suction fitting and a skimmer, while Pump 2 is generally attached to two suction fittings.

After plumbing is complete, secure the Hydro-Quip Equipment System with the appropriate hardware.

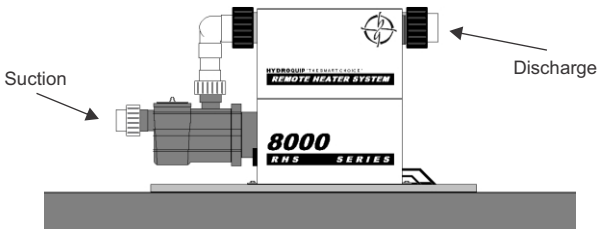

ELECTRICAL CONNECTIONS



IMPORTANT - The NEC and most local codes require that a “disconnect” be installed within “line-of-site” of the spa.

ELECTRICAL INSTALLATION DETAILS

Refer to the System Data Label for equipment voltage and maximum amperage draws.

Install proper size Ground Fault Circuit Interrupter (GFCI) or circuit breaker, then proper sized wiring and bonding wire. For Power conductor size, refer to the National Electric Code Table 310-16. For Ground conductor size, refer to the National Electric Code Table 250-122.

A bonding lug has been provided on the control box to allow connection to local ground points. To reduce the risk of electrical shock, a solid copper bonding wire should be connected from this lug to any metal ladders, water pipes or other metal object within 5 feet of the spa.

! WARNING - BE SURE THAT YOUR POWER SUPPLY CIRCUIT CAN ADEQUATELY HANDLE THE AMPERAGE YOU SELECT.

ELECTRICAL INSTALLATION

A qualified and licensed electrician in accordance with the National Electric Code (NEC) Article 680, Canadian Electric Code, and with any local codes must accomplish the electrical installation.

All connections must be made according to the electrical installation label on the outside of the control box (see page 20). Follow the instructions from the label if they are different than the instructions in this manual. If your electrician is not absolutely sure how to connect your system correctly, call your local dealer. Any mistake may be costly and invalidate your equipment warranty.

The GFCI (Ground Fault Circuit Interrupter) is a mandatory electrical safety device required for all portable spas and hot tubs as specified in the National Electrical Code Article 680-42. The GFCI in your particular installation may be installed at the electrical service panel or a separate sub-panel.

Your spa equipment requires a DEDICATED CIRCUIT. No other appliances or lights can be on this circuit. Refer to equipment data label for power supply requirements of your spa equipment.

Use copper conductors ONLY. The ground must be sized following the National Electric Code, Table 250-95.

For Power conductor size, refer to the National Electric Code Table 310-16.

NOTE: Due to the electrical requirements of some models, it may be required to SPLIT the incoming electrical service to accommodate the GFCI Circuit Breaker limits. Contact your electrician if you need additional information on this topic.

	* *							
Circuit & Breaker Rating	15A	20A	30A	40A	50A	60A	70A	80A
Maximum Amps	12A	16A	24A	32A	40A	48A	56A	64A
Minimum Wire Size	14	12	10	8	6	4	4	4

This is a Universal System and requires a Neutral wire therefore the service required is as follows.

Main Service Input (PCB): 240VAC - Line 1, Line 2, Neutral & Ground
Heater Service Input: 240VAC - Line 1, Line 2 & Ground

***Split Load - See Page 3**

ELECTRICAL CONNECTIONS

OPTION 1 Main Service Panel GFCI

20-60AMP
HARDWIRED

If the manufacturer of your main service panel makes a GFCI breaker, you may be able to add it to an open slot in the panel.

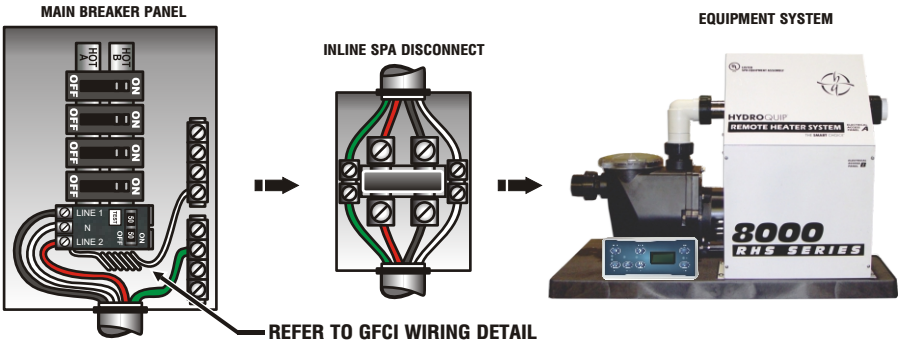

Power from GFCI breaker installed into main service panel to a service disconnect within line-of-site of the spa.

OPTION 2 Subpanel GFCI

20-60AMP HARDWIRED

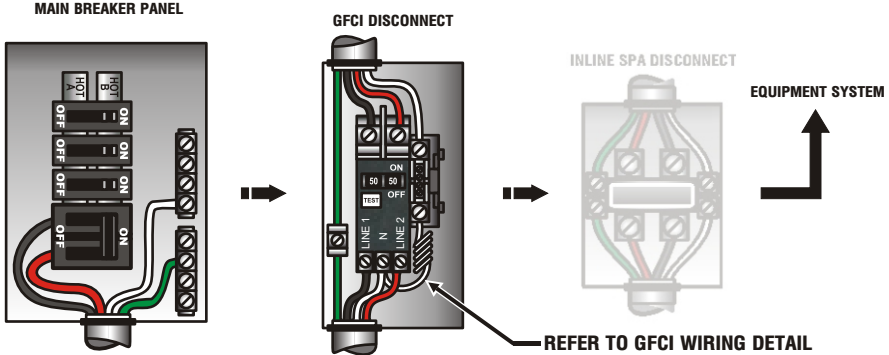

Power from main service panel to a GFCI subpanel within line-of-site of the spa. (Note: Most local codes will allow a GFCI subpanel to be a disconnect. If this is not the case in your installation, a disconnect must be provided.)

GFCI WIRING DETAIL

When a GFCI circuit breaker is used in the installation of your spa, it is important that it has been properly wired. Often this component has been improperly wired causing the breaker to trip the instant the system is turned on. Below is an illustration of a typical GFCI breaker installation.

WARNING: Refer to Circuit Breaker Manufacturers installation instructions. This illustration is meant to be a guide for Field Technicians and is not intended to override or substitute the instructions supplied with the circuit breaker.

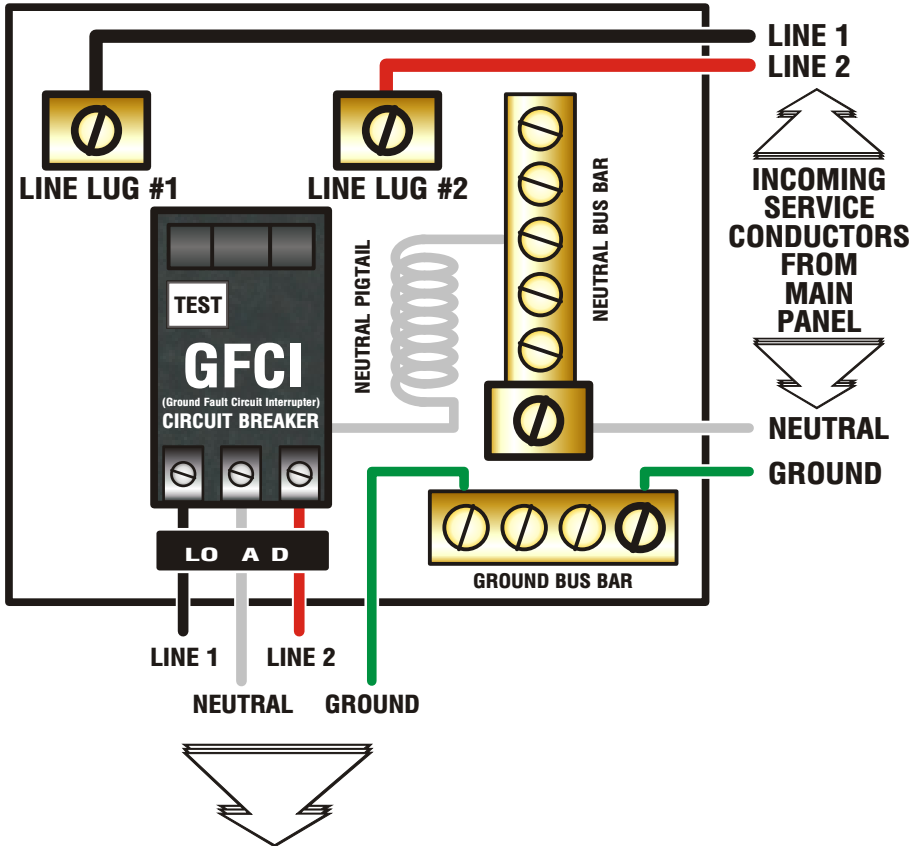

MAIN INPUT / HEATER INPUT SERVICE

LOAD NEUTRAL MUST BE CONNECTED DIRECTLY TO GFCI AS SHOWN

ELECTRICAL CONNECTIONS (Split)

Due to amperage requirements a split circuit connection may be required.

Pumps, blower, etc are isolated to the “**Main Input Service**” connections. This connection requires a L1, L2, Neutral, and Ground (See Illustration Below)

The heater connection is isolated to the “**Heater Input Service**”. This connection requires a L1, L2, and Ground connection. (See Illustration Below) Connect incoming voltage to the pre-installed leads from the “**Heater Input Service**”.

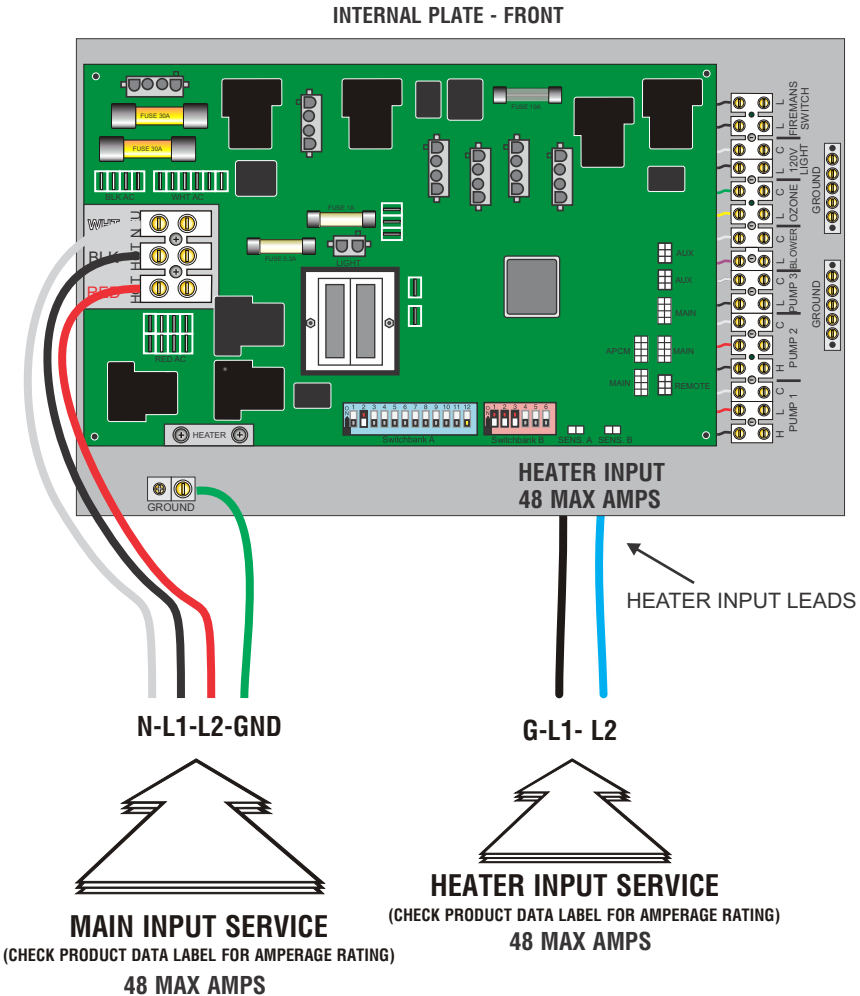

ELECTRICAL CONNECTIONS (Single)

IMPORTANT - When a "split circuit" connection cannot be utilized due to retrofit or other issues, connect "single circuit" connection as shown below.

If you are connecting a system with an 11kW heater utilizing the single circuit application, you will have to change dip switch #2 setting (see Fig. A).

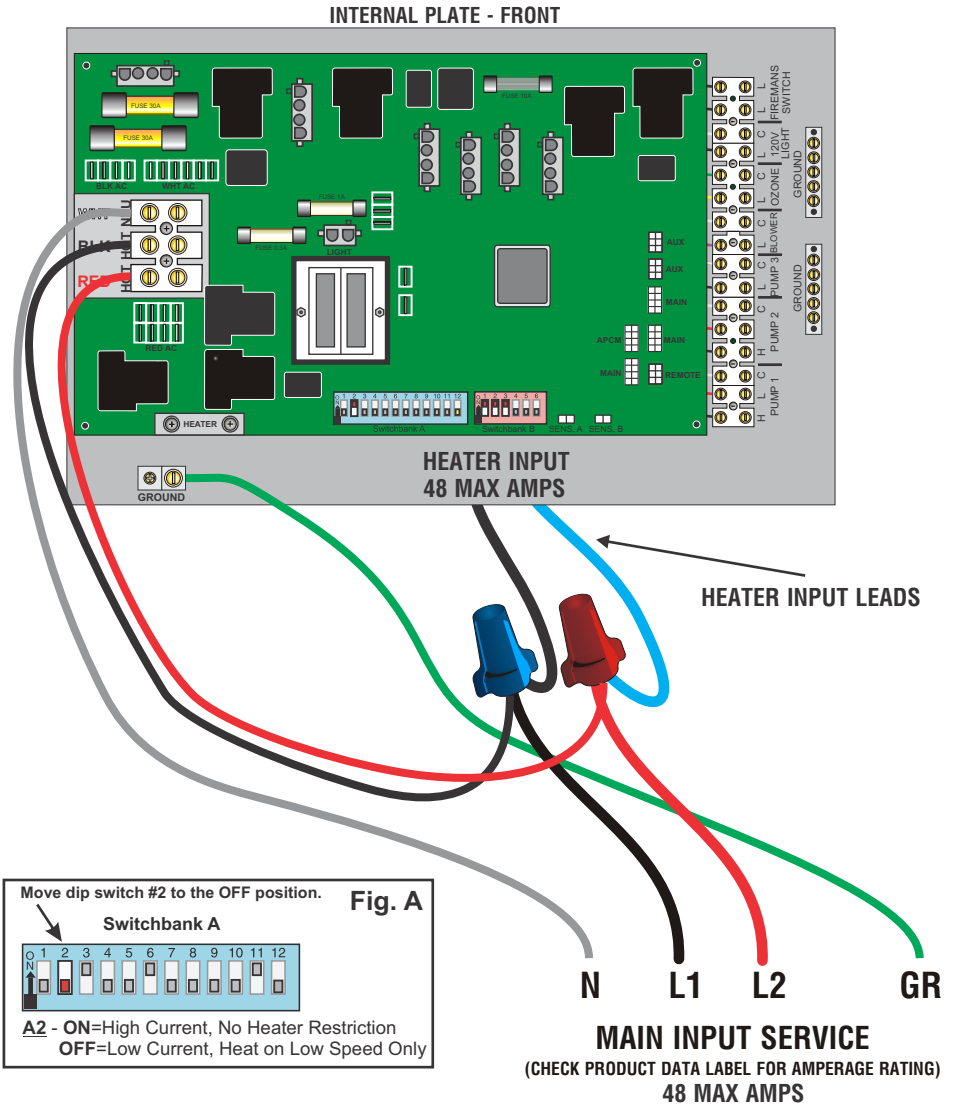

GAS HEATER CONNECTION

Warning: Do not install a spa that utilizes a natural gas or propane heater without proper venting. These heaters require adequate ventilation and must be installed according to the heater manufacturers instructions and to local building codes.

Warning: Gas heaters **MUST** be installed **AFTER** the control system as shown below. Fig.1

Note: Many gas heaters require a separate electrical service for proper operation, the Hydro-Quip "Gas Heater Control Circuit" does NOT provide voltage to any gas heater circuits. Always refer to the manual included with your gas heater for proper installation.

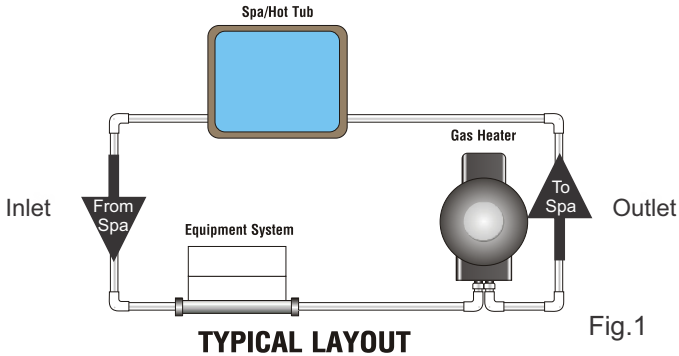

Fig.1

Gas Heater Control Circuit

The Hydro-Quip control system contains a Gas Heater Control Circuit Fig.2. This circuit is a passive or "dry contact" circuit, do not apply line voltage to this circuit. Connect this circuit to the gas heater's Fireman Switch or Fireman Circuit. *Refer to the instructions provided with your gas heater to identify the circuit / switch and correct wiring connection. Additional programming may be required to the gas heater to utilize an auxiliary control system.

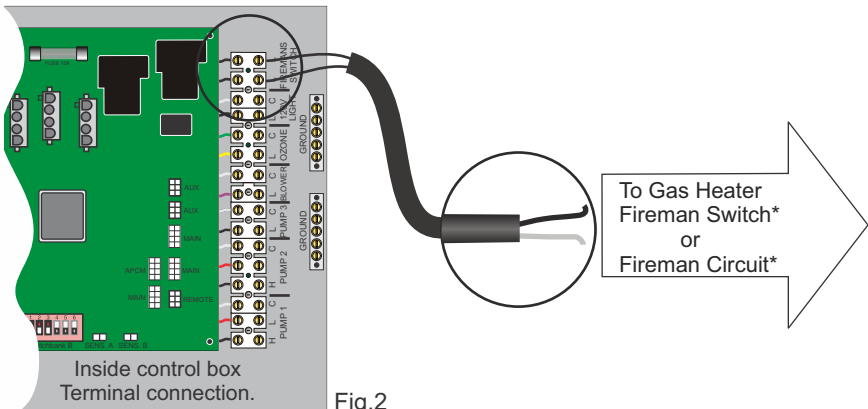

Fig.2

IMPORTANT: Applying line voltage to Gas Heater Control Circuit voids all warranty.

PUMP CORD INSTALLATION

The equipment system has been provided with a pump power cord and liquid-tight conduit assembly. This is to be used on the main 2-speed pump supplied with the system. Any other components or accessories attached to the equipment system should be attached in a similar manner.

Follow the simple instructions below to quickly attach the cord assy to the pump:

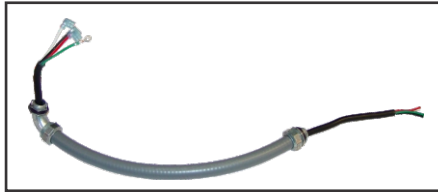

Cord Assy included for Pump 1

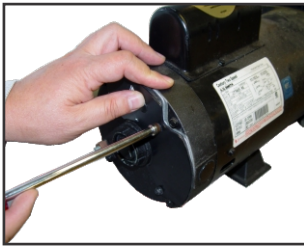

1) Remove the terminal cover off the back off the pump

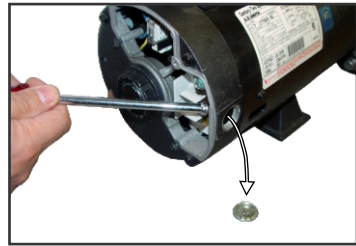

2) Remove the conduit hole cover

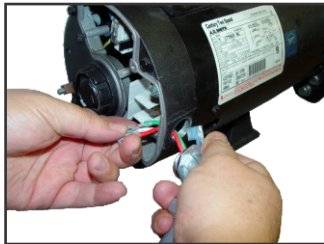

3) Route the power wires through the conduit hole and pull toward you to allow for the cord assy to be rotated for tightening.

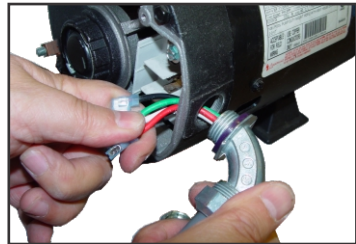

4) While holding the wires as shown thread the liquid-tight connector into the pump until secure then connect the power wires to the pump per the label on the pump.

WIRING NOTE:
RED = LOW
BLACK = HIGH
WHITE = COMMON
GREEN = GROUND



5) Route the other end of the conduit through an empty knock-out and secure with lock-nut. The cord inside will route up to the terminal strip inside the upper portion of the enclosure.

AIR BLOWER INSTALLATION (Optional)

CAUTION: The air blower must be connected **ONLY** to the spa's air distribution plumbing. Connecting the air blower to the air piping associated with the hydrotherapy jets will create a hazard by providing a path for high-pressure water to be forced into the blower motor. This will result in damage to the air blower and create an electrical shock hazard.

- The air blower must be installed to **ensure that water cannot enter the air blower motor**. This can be accomplished by installing a single or double air loop that incorporates a check valve.

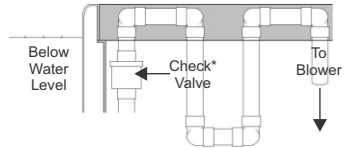
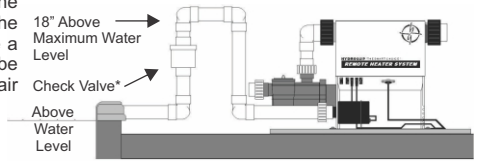

SYSTEM CONFIGURATION

The control circuits for components not included with the system have been pre-configured for 120V at the factory. This is to prevent accidental damage to equipment. A 240V component connected momentarily to a 120V power supply will not be damaged. A 120V component connected to a 240V power supply can be damaged immediately. For this reason Hydro-Quip cannot be held responsible for damage caused due to mis-wire.

Below are illustrations and instructions for converting the universal circuits of your control. Hydro-Quip utilizes color coded connectors to help identify each circuit. Simply locate the colored connector on the Neutral (white) wire from each component receptacle on the PCB. Using the wiring diagram provided with each control (located inside of cover), remove the Neutral connector from its **WHT AC / Neutral** position and reconnect to an empty position at the **RED AC / Line 2** connection block. Once accomplished the conversion is complete, repeat these steps for each component that operates on 240V.

- Remove connector from WHT AC connection
- Reinstall connector onto RED AC connection

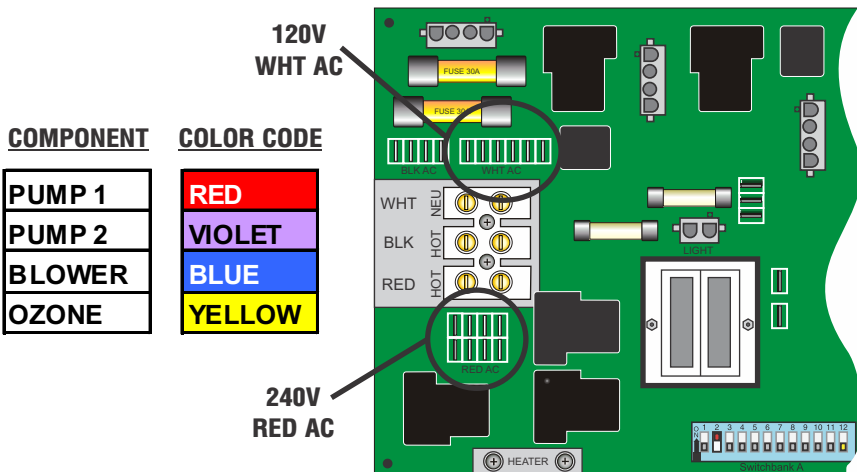

COMPONENT CONNECTION

The system is set up to have components hardwired to a terminal strip inside the upper enclosure. **Liquid tight conduit must be used on all externally added field connections exposed to the weather.** Route and connect the conduit to the knock-outs in the back of the lower box. The wires will then enter the bottom of the upper box through another set of knock-outs. Connect the component(s) accordingly to the corresponding position on the terminal strip and tighten securely. Refer to the included wiring diagram as needed. All components not included with the system are set at the factory for 120V. Verify the voltage of the additional component(s) and adjust supply voltage if necessary by referring to System Configuration on page 10.

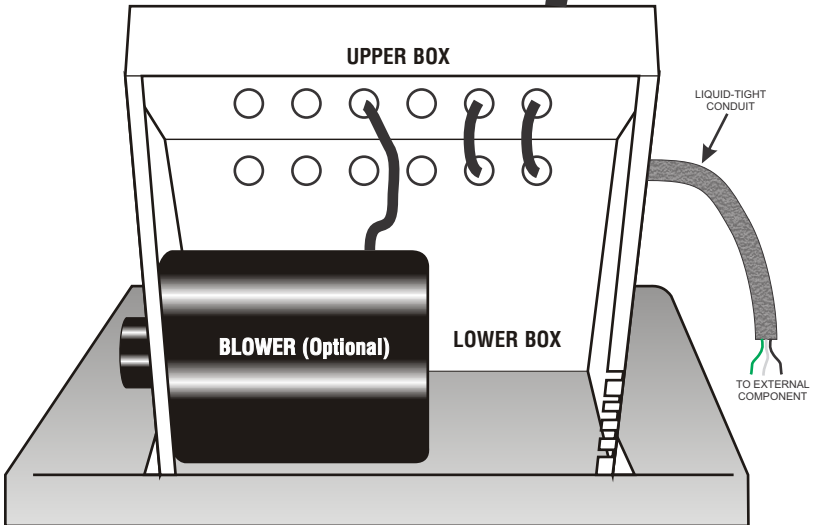
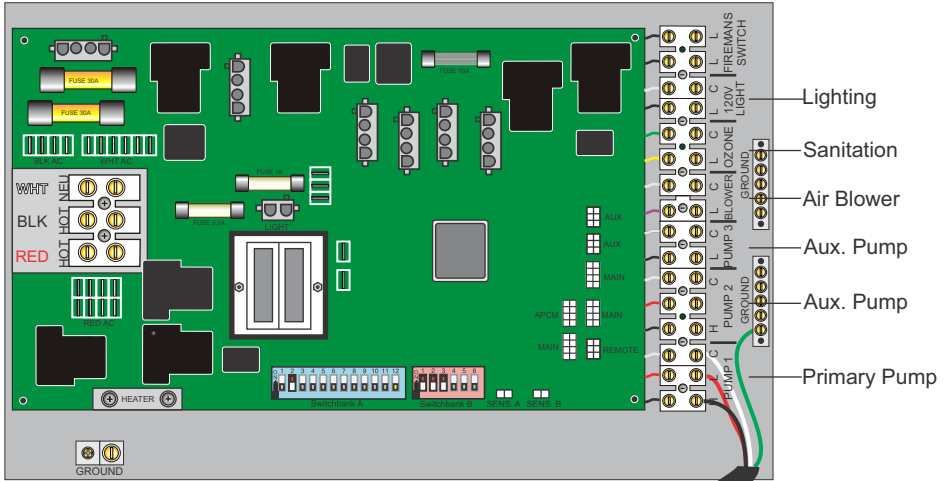

8700 SERIES - COMPONENT CONFIGURATION OPTIONS

DEFAULT CONFIGURATION:

- Pump 1 - 2 Speed
- Pump 2 - 1 Speed
- Blower

Internal Configuration Required:

No addition configuration required

Switchbank A

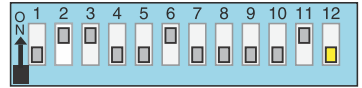

Switchbank B

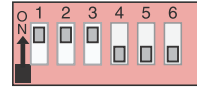

OPTION 1:

- Pump 1 - 2 Speed
- Pump 2 - 2 Speed
- Blower

Internal Configuration Required:

- Modify Dip-Switches as shown**
- Remove **Pump 3** plug from auxiliary PCB
- Move **BLOWER (J3)** to auxiliary PCB.
- Connect **LOW SPEED PUMP 2** wire (free hanging 4 pin AMP plug w/**RED** Wire) to Blower Connection (**J3**)

Switchbank A

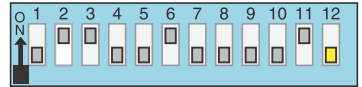

Switchbank B

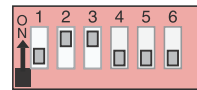

OPTION 2:

- Pump 1 - 2 Speed
- Pump 2 - 2 Speed
- Pump 3 - 1 Speed

Internal Configuration Required:

- Modify Dip-Switches as shown**
- Disconnect **BLOWER (J3)**
- Connect **LOW SPEED PUMP 2** wire (free hanging 4 pin AMP plug w/**RED** Wire) to Blower Connection (**J3**)
- NOTE: Pump 3 requires additional button (HQ PT# 34-0224)

Switchbank A

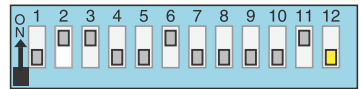

Switchbank B

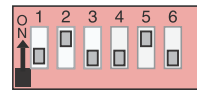

OPTION 3:

- Pump 1 - 2 Speed
- Pump 2 - 1 Speed
- Pump 3 - 1 Speed
- Blower

Internal Configuration Required:

- Modify Dip-Switches as shown**
- NOTE: Pump 3 requires additional button (HQ PT# 34-0224)

Switchbank A

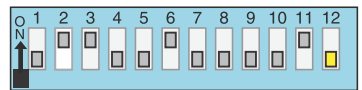

Switchbank B

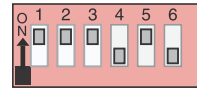

****Persistent Memory must be reset after making changes to the dip switches. To reset Persistent Memory power the system down, turn Switch A12 "ON", power up system and wait for "P R" to be displayed on the keypad. Then set switch A12 to "OFF" (this can be done with the power to the system "ON" as long a non-conductive tool is used).**

8700 SERIES - PROGRAMMING

It is possible to change various operational characteristics of the control system using the Dip Switch Blocks located on the lower edge of the main control PCB (Printed Circuit Board) inside the control box. Persistent Memory must be reset when changing the dip switches. To reset Persistent Memory power the system down, turn Switch A12 "ON", power up system and wait for "P R" to be displayed on the keypad. Then set switch A12 to "OFF" (this can be done with the power to the system "ON" as long a non-conductive tool is used).

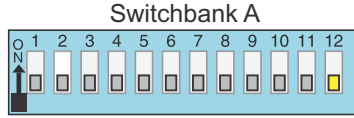

DIP SWITCHBANK A:

- A1** - Test Mode (normally Off)
- A2** - ON=High Current/no Heater Restrictions
OFF=Low Current/heat With Low Speed Only
- A3** - ON=Filtration Program By Duration
OFF=Filtration Program By Time (special Keypad Required)
- A4** - ON=24 Hour Clock/Military Time
OFF=12 Hour Clock/Standard AM/PM Time
- A5** - ON=Celsius Temp Readout
OFF=Fahrenheit Temp readout
- A6** - ON=30 Minute Timeouts
OFF=15 Minute Timeouts
- A7** - ON=Cleanup Cycle ON (30min after spa use Pump1 & Ozone for 1 hour)
OFF=Cleanup Cycle OFF
- A8** - ON=Ozone Suppression for 1 hour when Pump or Blower Press
OFF=Ozone Suppression OFF
- A9** - OFF/NOT USED
- A10** - OFF/NOT USED
- A11** - ON=Ozone with Filtration Cycles
OFF=Ozone with Low Speed Pump
- A12** - ON=Persitant Memory Unlocked
OFF=Persitant Memory Locked (Normal Position)

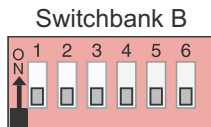

DIP SWITCHBANK B:

- B1** - ON=Single Speed Pump 2
OFF=Tw0 Speed Pump 2
- B2** - ON=Pump 2 Enabled
OFF=Pump 2 Disabled
- B3** - ON=Blower Enabled
OFF=Blower Disabled
- B4** - ON=Fiber Wheel Enabled (additional kit required)
OFF=Standard Light Output
- B5** - ON=Pump 3 Enabled
OFF=Pump 3 Disabled
- B6** - ON=ML900 Panel Support/Scrunching Enabled
OFF=Normal Panel Layout

NOTE: Not all settings are available and are Keypad or Auxiliary PCB Dependent

SPA LIGHT INSTALLATION

To offer the most flexibility, Hydro-Quip configures each 8000 Series system so that it can accept a 120-Volt light. *The 8000 series can also be configured for a 12 volt light.* A terminal block has been provided for connection purposes. Connect your light using the illustration below.

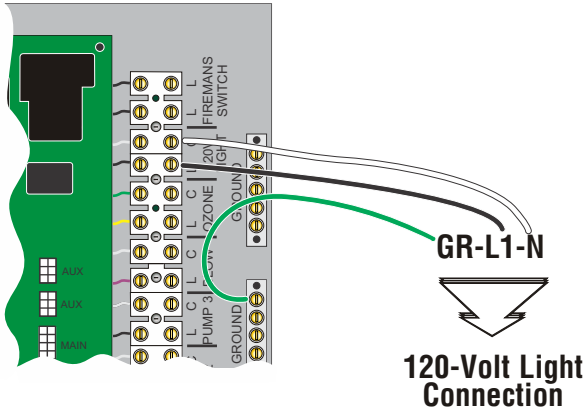

The following steps are required for converting the light circuit from 120V (default) to 12V.

- 1) Power off spa utilizing the circuit breaker.
- 2) Remove Light Jumper J46 from pins 1&2 and place the Light Jumper J46 on pins 2&3.
- 3) Jumper wire W9 is connected to J48 by default. Remove the jumper wire from J48 and place on J45.
- 4) Power on spa.

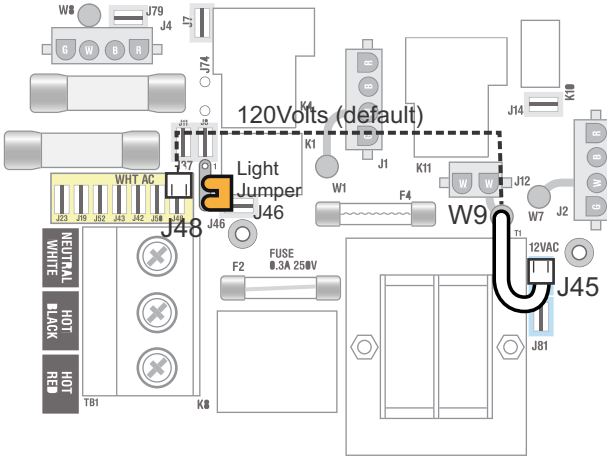

Light Jumper J46

B 120Volts (default)
Jumper covering pins 1&2

B 12Volts
Jumper covering pins 2&3

Jumper Wire W9

WHT AC 120Volts (default)
J48

12VAC
J45

SPASIDE CONTROL INSTALLATION

If required, cut out a 6 3/8" x 2 3/8" hole in the spa shell using the Spaside Cutout Template that has been provided with the system.

- The mounting area must be above the maximum water level of the spa and in an area with good drainage to prevent any standing water on or around the spaside.
- The spaside should never be submerged.
- The spaside should be protected from extended periods of exposure to sunlight.
- Do not step or stand on the spaside

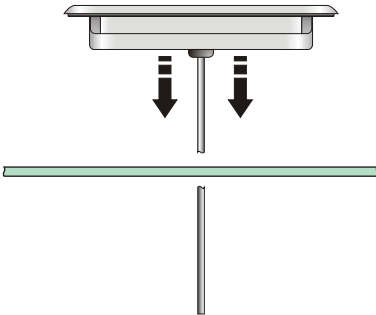

Step 1 - Clean area and insert spaside control.

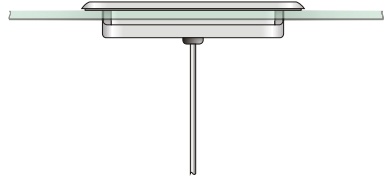

Step 2 - Remove the double sided adhesive from the back of the spaside. Make certain the spaside is straight and adhere to the spa shell.



OVERLAY MAY VARY

Step 3 - Remove protective film from display window then clean the face of the spaside.

Now carefully align and apply the label.

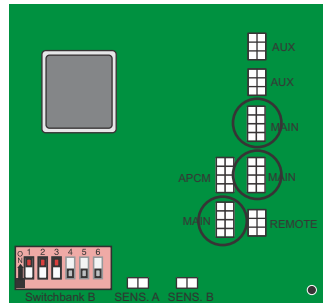

Step 4 - Connect spaside to an empty connection marked "Main"

SYSTEM STARTUP

System Startup Procedures:

Using the "System Operation Manual" provided with the unit, complete the following procedures:

- 1) *Read and familiarize yourself with the system Operation manual.*
- 2) *Unplug the power cord (120-volt system only) or turn the electrical power "OFF" at the service or breaker panel (120 or 240 volt permanently connected units.)*
- 3) *Open all WATER shut-off valves.*
- 4) *For spas equipped with a hose bib or drain valve, make sure that it has been closed.*
- 5) *For spas equipped with in-line or pressure water filters, make sure that the filter nut, housing drain plug, and air relief valve are closed and tight.*
- 6) *Using a standard water hose, fill the spa with fresh tap water to the level recommended by the spa manufacturer.*
- 7) *If pump is equipped with a strainer pot, remove the lid and fill the pump pot and volute up to the inlet with water. Clean the cover, o-ring and sealing surface of the pump pot and re-install lid. (**DO NOT** over tighten with tools)*
- 8) *Inspect all plumbing connections and lines for any sign of water leaks.*
- 9) *Close all AIR control valves. WARNING: Do not confuse with WATER shut-off valves.*
- 10) *Plug the unit into the proper outlet (120-volt system) or turn on the breaker at the electrical service panel (240-volt system).*
- 11) *On units with a Ground Fault Circuit Interrupter (GFCI), check the GFCI by pressing the "Test" button on the face of the device. The "Reset" button should pop out. **The equipment should not operate.***
- 12) *Activate the equipment by pressing the "Reset" button on the GFCI. (If the jet pump(s) or blower is operating, switch them off).*
- 13) *Adjust temperature to the lowest setting.*
- 14) *Press the "JET PUMP" switch to run on high speed. Allow to run until you achieve a strong, steady water flow (free of air bubbles). **Check for leaks.***
- 15) *On systems with a pressure filter, bleed off the trapped air by opening the Air-Relief valve. You will notice a steady flow of water when the air has been bled completely.*
- 16) *Switch the "JET PUMP" off.*
- 17) *If equipped, switch the "AIR BLOWER" on to verify that it is working, then switch it off.*
- 18) *If equipped, switch the "LIGHT" on to verify that it is working, then switch it off.*
- 19) *If equipped, switch the "AUXILIARY PUMP" on to verify that it is working, allow to run until all air is evacuated from the plumbing system, then switch it off. **Check for leaks.***
- 20) *Adjust temperature to the desired set point for comfortable use of the spa. The pump low speed and heater will activate until the set point has been reached.*

It is now time to turn over operation of the spa to the homeowner. An Operations Manual has been provided with the system. See next section for basic troubleshooting tips.

TROUBLESHOOTING

The following describes situations and possible solutions to common problems you may encounter as a spa owner. **Note: your system may not** include all components listed.

NOTHING OPERATES

Main Breaker is OFF - *Set to On.*
Sub-Panel Breaker Off - *Set to On.*
System GFCI Off - *Set to On.*
Power switch in Off position - *Set to On.*
Components not plugged in - *Plug in components.*
Power cord not plugged in - *Plug in power cord.*
System Fuse Blown - *Contact your installer.*

GFCI TRIPS IMMEDIATELY

For correct GFCI breaker wiring, refer to page 5 for details.

NO LOW SPEED PUMP OPERATION

Pump 1 Not Plugged-In - *Plug in Pump 1.*
Pump 1 Fuse Blown - *Contact your installer.*
Pump 2 Not Plugged-In - *Plug in Pump 2.*
Pump 2 Fuse Blown - *Contact your installer.*

NO JETS OR BLOWER OPERATION

Blower or Pump Not Plugged-In - *Plug in the Blower or Pump.*
Pump or Blower Fuse Blown - *Contact your installer.*

NO THERAPY JET OPERATION

Water Shut-Off Valves are Closed - *Open Shut-Off valves.*
Jets Not Properly Adjusted - *Adjust Jets properly.*
Diverter Valve Not Properly Adjusted - *Adjust diverter valve properly.*
Thermal Overload Tripping - *Check for restricted flow of water.*

NO, LOW OR SURGING WATER FLOW

Air Lock in Plumbing System - "Bleed" or prime the system.

Restricted Flow - Insure that the water shut-off valves are open and that suction fittings are not blocked by debris.

Low Water Level - *Increase water level to recommended level.*

Pump Unions Loose - *Tighten or contact your installer.*

NO LIGHT OPERATION

Light Bulb Defective - *Replace bulb or contact your installer.*

Reflector has Fallen Off - *Replace deflector or contact your local dealer.*

Light Not Plugged-In - *Plug in the Light.*

NO HEAT

Temperature Not Set Correctly - *Adjust "Set Point" Temperature.*

System Power Restriction - *Depending on available power, the spa may have interlocks in place to shut off the heater when the pumps are switched to high speed.*

HIGH HEAT

Temperature Set Too High - *Adjust "Set Point" Temperature.*

High Ambient Temperature - *Remove spa cover.*

WATER LEAKS

Spa Overfilled - *Adjust water level.*

Drain-Valve Left Open - *Close drain valve.*

Couplings or Unions Loose - *Tighten or contact your installer.*

Pump Seal Leaking - *Contact your installer.*

Plumbing / Connections Leaking - *Contact your installer.*

Water Leaking from Spaside Control - *Contact your installer.*

Water in Air Blower Plumbing - *Contact your installer.*

EXTREME WEATHER CONDITIONS

Although the advanced nature of the control software should allow trouble free operation all year round, there are some considerations for extreme weather conditions that needed to be addressed.

Hot Weather Conditions

Hot weather can cause the a number of issues with the operation of the spa and equipment.

Water temperature can be elevated to a very high temperature simply due to the outside air temperature. If this occurs you may need to remove the insulated spa cover, add cooler water and/or turn on the Air Blower or Therapy jets to help dissipate the heat within the water. In extreme conditions, you may wish to consider a chiller or evaporative cooler to help control the water temperature.

The **pump motors** supplied with your system incorporate internal Thermal Overload switches to prevent damage to the motor during times of extreme heat. The motor may operate for a period of minutes and then turn off due to the internal switch. If this happens, the internal switch will cool and reset within a period of time and resume operation.

The system **temperature sensors** may sense the high ambient air temperature and may prevent the system from operating. In these cases, it may be required to completely enclose and properly ventilate the system to prevent the effects of direct sunlight and/or extreme heat.

Direct Sunlight on System

In warm climates, the sun hitting directly on the system can elevate the temperature within the control enclosure to the point that certain circuit will not operate. It may be required to completely enclose and properly ventilate the system to prevent the effects of direct sunlight.

Freezing Temperatures

If power is lost during very cold conditions, exposed plumbing may freeze in a very short time. In certain climates, it may be required to completely enclose and properly ventilate the system while also insulating all exposed plumbing lines to prevent freezing of the water within the pipes. If weather conditions are severe and power cannot be assured, it is recommended that a local pool and spa specialist be contacted to have the spa be completely drained and/or winterized.

Loss of Power

If power is lost due to weather or storms and there is no indication of when the power will be restored, it is recommended that the spa be drained to prevent damage to the plumbing from freezing water. It may be necessary to disconnect a few plumbing points to allow entrapped water to drain completely.

Snow

Assure that the system is kept clear of all accumulated snow fall as the system requires proper and adequate ventilation at all times. In certain climates, it may be required to completely enclose and properly ventilate the system.

SYSTEM DATA LABEL

The system data label is located on the control box. This label is very important and contains information you will need to establish your electrical service. The voltage and amperage ratings are shown on the bottom of the label. Product, Model, Serial and Code numbers are also shown on the label.

Note: *This information will be necessary if you should ever have to request warranty or any other type of service.*



HYDROQUIP™
THE **SMART** CHOICE™

ORDER CODE: _____

MODEL: _____

SERIAL: _____

CODE: _____

VOLTS: _____

AMPS: _____

PRODUCT: _____

REFER TO NEC FOR
BREAKER SIZING

WARRANTY INFORMATION

To all original purchasers, **HYDRO**QUIP warrants its products to be free from defects in material and workmanship for a period of two (2) years from the date of purchase.

HYDROQUIP will repair or replace the part, which in our opinion, is defective.

This warranty excludes damage as a result of: normal wear, freezing, low voltage, chemical abuse, accident, negligence, alteration, improper installation, use or care.

To obtain warranty service, return defective products within the warranty period to **HYDRO**QUIP.

Purchaser is responsible for removal or reinstallation labor, freight charges, or any other such costs incurred in obtaining warranty service.

HYDROQUIP assumes no responsibility for incidental or consequential damages. Some states do not allow the exclusion of incidental or consequential damages, so the above limitations and exclusions may not apply to you. This warranty gives you specific legal rights and you may also have other rights, which vary from state to state.

**THE SPA DEALER MAY PROVIDE A DIFFERENT WARRANTY,
CONTACT YOUR SPA DEALER FOR DETAILS**



HYDROQUIPTM

510A N. Sheridan Street · Corona, CA 92880-2024

Email: info@hydroquip.com · Internet: <http://www.hydroquip.com/>

Telephone: 951.273.7575 · Fax: 800.332.7190